



AD725 Evaluation Board Operating Instructions

Input Connections

The AD725 Evaluation Board can be powered by a 5V dc wall-type power supply that connects to P3. The center pin of connector P3 is positive. Optionally it can be powered by +5V and ground via P6.

The male end of the VGA extender cable is plugged into the source of RGB video (VGA port of a PC). The female end connects to P2 on the AD725EB. A VGA monitor can be plugged into P1 if desired for convenient switching between monitors (TV and VGA).

SW1 (Bypass / Encode) can be used to select between the AD725 encode path or the VGA bypass path. The HSYNC signal is switched along with the RGB signals. A 10k series resistor in the path of VSYNC prevents loading of this signal when power is not supplied to the AD725.

An RGB Multisync monitor that can work at 50 or 60 Hz interlaced and VGA resolution should be able to properly display interlaced RGB video output. However, most RGB monitors will not be able to display interlaced video. Likewise, virtually all TV's can not display non-interlaced video. NTSC and PAL do not have non-interlaced definitions.

Subcarrier and Video Standard

The AD725 has only one subcarrier option. It must be 4 x fsc of either the NTSC or PAL frequency and must be an actively driven (TTL compatible) logic-level signal. The evaluation board comes with a 14.31818 MHz oscillator installed in position Y2 for NTSC operation. A 17.734480 MHz oscillator can be installed in position Y1 for PAL operation.

The NTSC/PAL selector switch (SW2) selects between the two oscillators and provides the proper logic signal to pin1 (STND). This switch also selects the frequency of the luma trap formed by L1, C10, C14, D1 and R2. Refer to the AD725 data sheet for further information on luma trap operation.

Power Down

J1 is used to program the power-down status of the AD725. For normal operation, no jumper should be installed. A pull-up resistor will keep pin5 (PD) in the high state. Installing J1 shorts pin5 to ground which powers down the AD725.

Output Connections

There are two options for video out. Only one is necessary at a time, but both can be used simultaneously. Composite video is output on the RCA (phono) connector. It is ac-coupled via a 220 uF capacitor and back-terminated with 75 ohms. The supplied cable can be used to connect this signal to the baseband video input of a TV which will provide a 75 ohm termination.

S-video (Y/C Video) is available on the 4-pin circular DIN connector. The luminance (Y) and the chrominance (C) are also ac-coupled and back terminated with 75 ohms. This output can be connected to the S-Video input of a TV with the supplied cable.

In general, S-Video will result in better picture quality due to limitations of the of the composite video circuitry used in TV monitors. It is highly recommended that S-Video be used whenever it is a feasible option.

Software

The software used for the AD725EB was developed for previous encoder products, but is still usable for the AD725, however, it must be run from DOS. It is not compatible with Windows 95. The software can be run from the floppy disk, or can be installed on a hard drive. By running the INSTALL program, the software will be loaded into a directory called TV.

A TSR (Terminate and Stay Resident) program called TV.EXE is used to change the scanning of the graphics controller to interlaced format, 60 Hz for NTSC or 50 Hz for PAL, and performs the appropriate vertical scaling to make the VGA format fit into a composite video frame. The software works with most popular graphics controller chips, although it is not guaranteed to work with every one. In particular, many laptop computers will not be compatible, because of conflicts with driving the LCD in addition to the VGA monitor.

To run the TSR with NTSC scanning, the command to use is TV -N [RETURN], and for PAL it is TV -P [RETURN]. The TSR can be unloaded by command TV -U [RETURN], but this can only be performed from the non-interlaced scanning mode.

Once the TSR is running, the hot-keystroke command ALT-BACKSPACE will toggle the graphics controller between non-interlaced (VGA) mode and interlaced (TV-video) mode.

The DEMO file contains a collection of pictures for viewing the TV image quality. Alternately, any other programs can be run to test the performance.

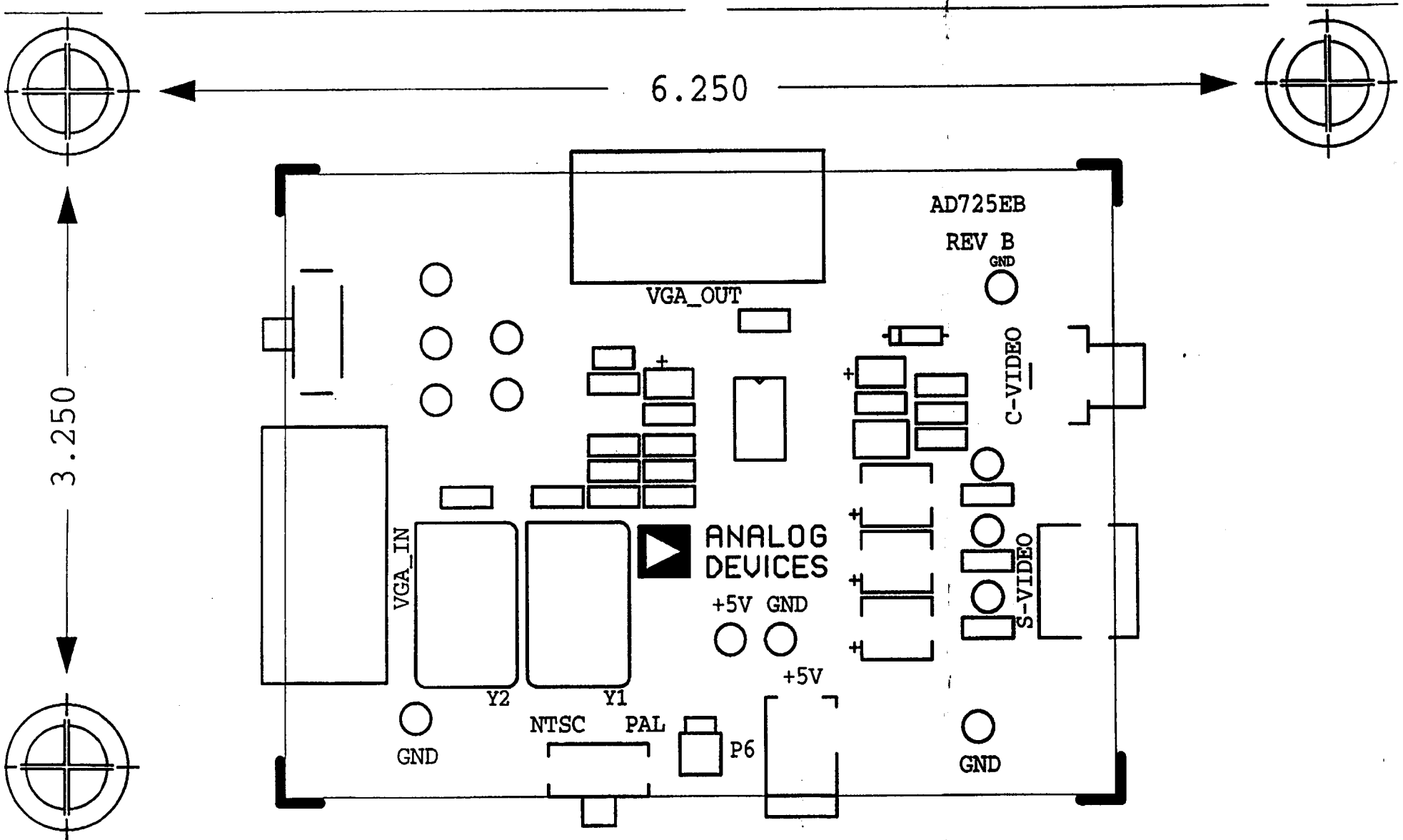

	ANALOG DEVICES	<p>AD725 EVALUATION BOARD REV B</p> <p>SILKSCREEN - PRIMARY SIDE</p> <p>SHEET 2 OF 6</p>
--	---------------------------	---

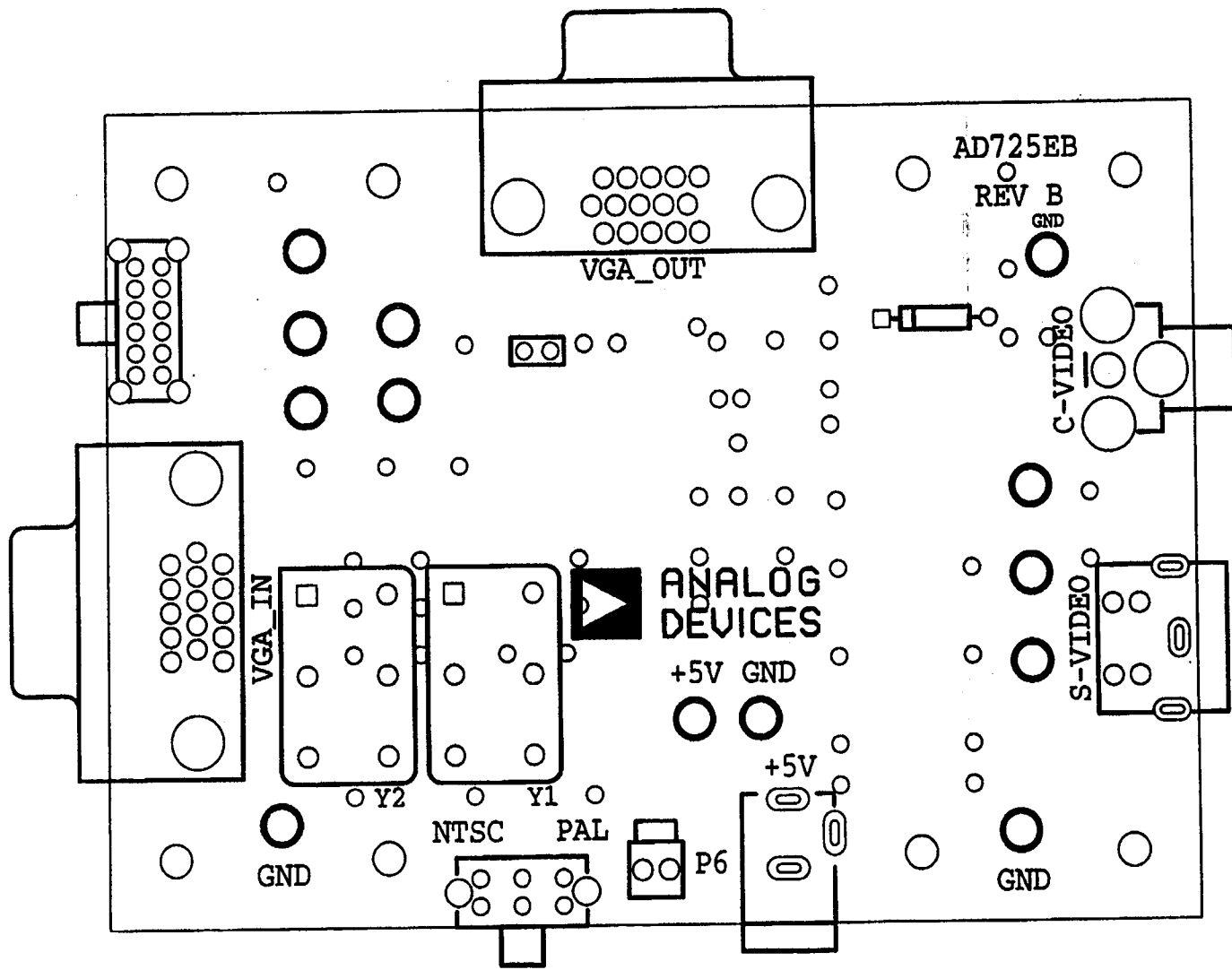

ASSEMBLY DRAWING
 AD725 EVALUATION BOARD REV B

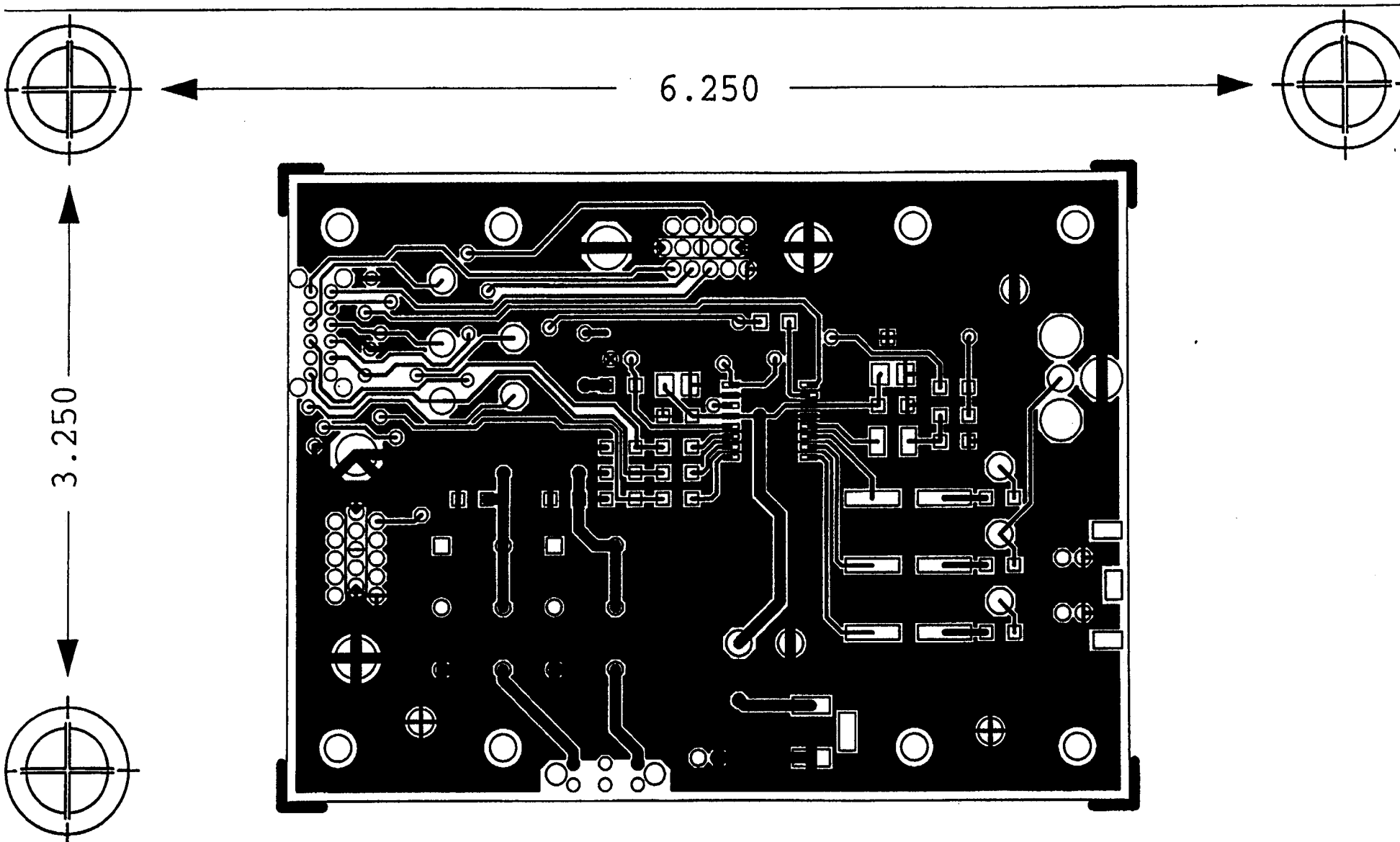

ANALOG
DEVICES

AD725 EVALUATION BOARD REV B

PRIMARY SIDE

SHEET 4 OF 6

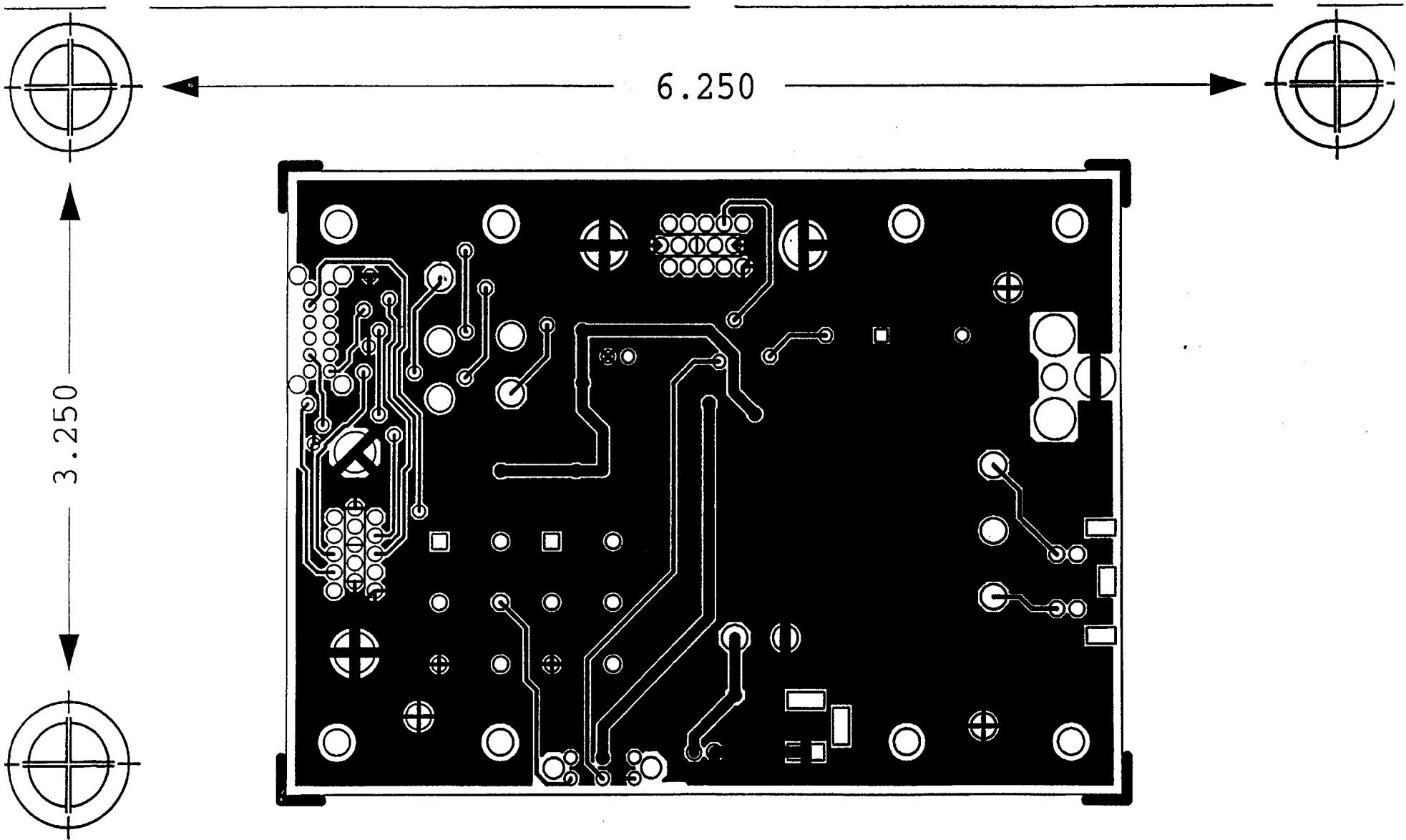

ANALOG
DEVICES

AD725 EVALUATION BOARD

REV B

SECONDARY SIDE

SHEET 5 OF 6

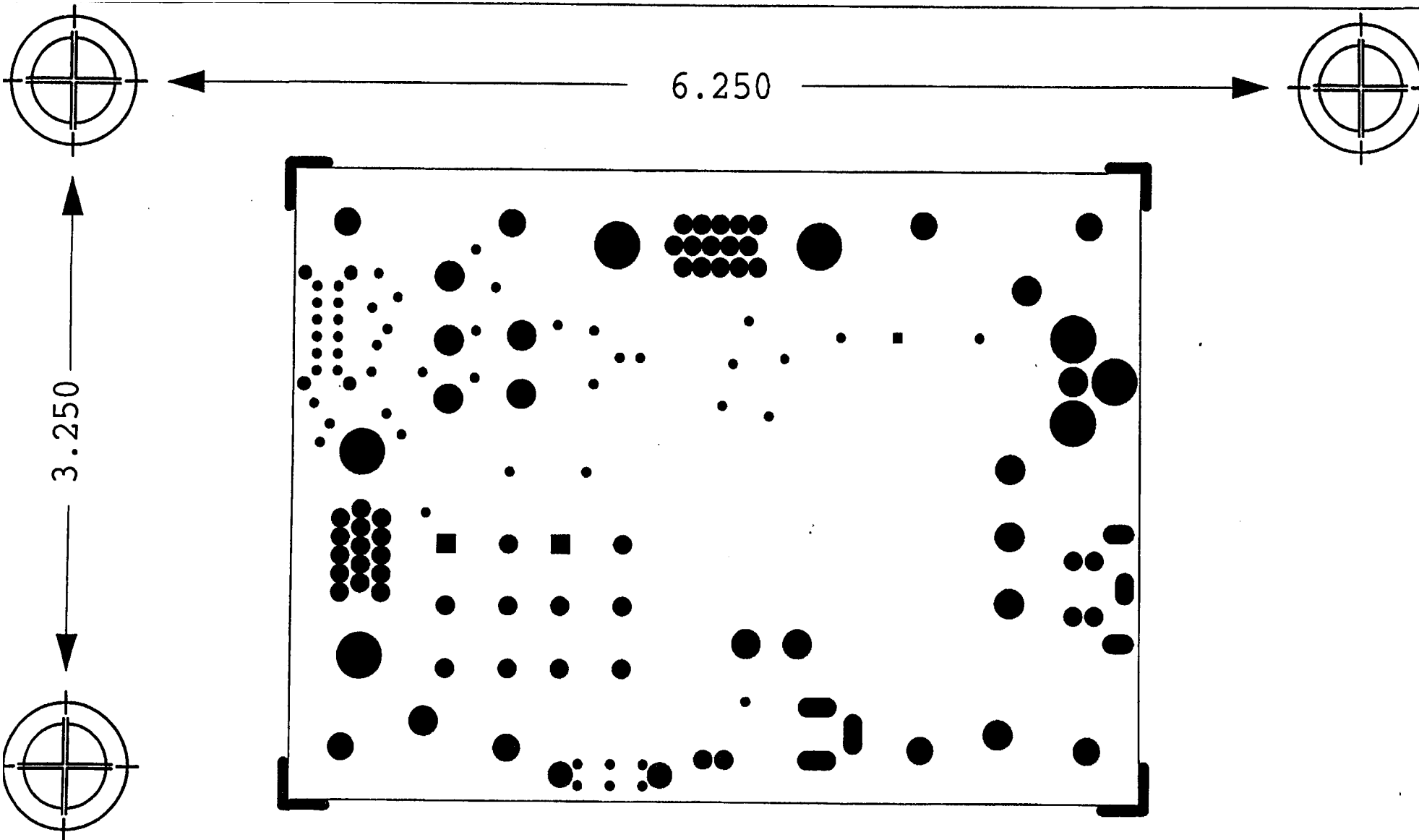

ANALOG
DEVICES

AD725 EVALUATION BOARD REV B
SOLDERMASK - SECONDARY SIDE
SHEET 6 OF 6

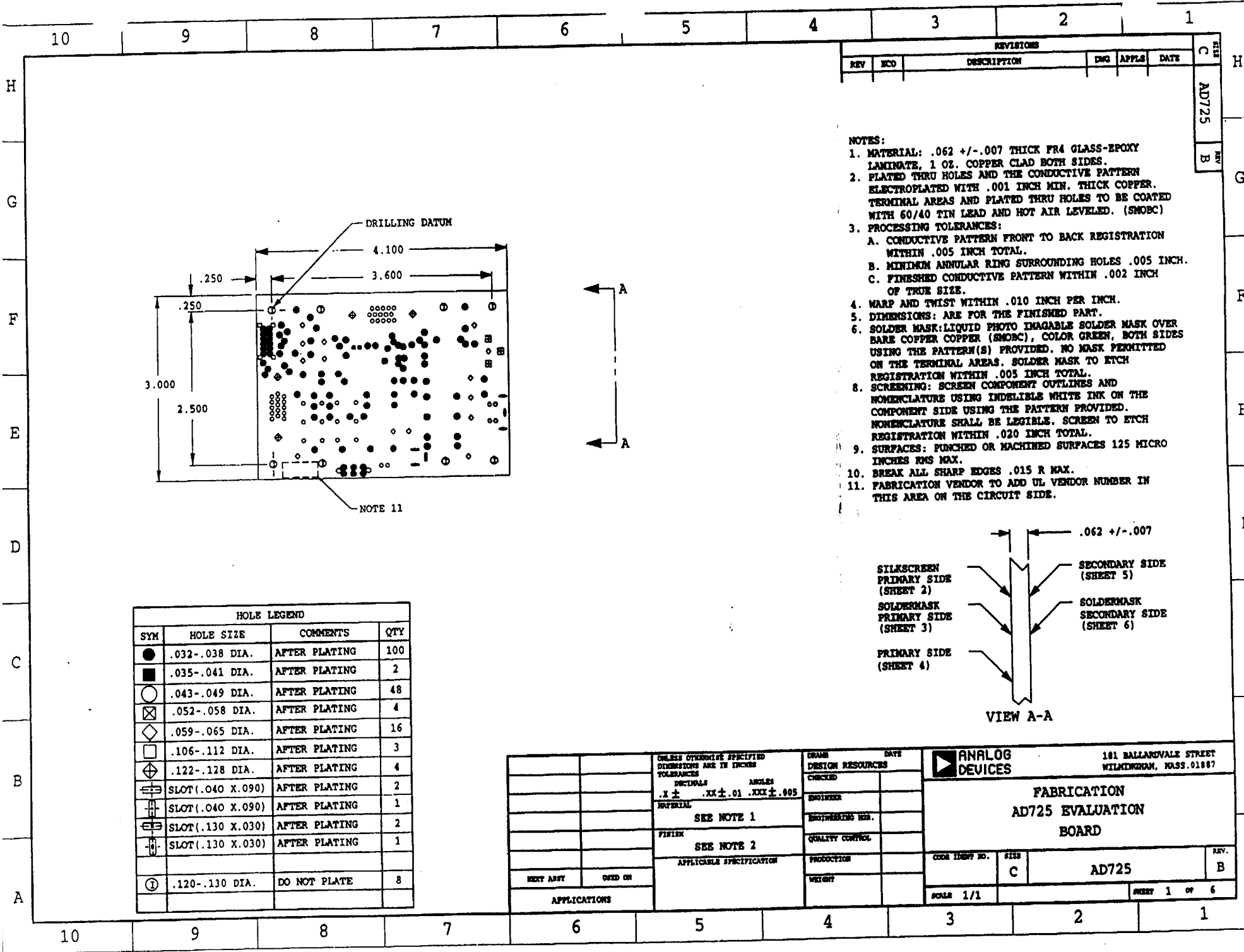

REVISIONS					
REV	ECO	DESCRIPTION	ENG	APPLS	DATE

REV	C	AD725
REV	B	

- NOTES:
- MATERIAL: .062 +/- .007 THICK FR4 GLASS-EPOXY LAMINATE, 1 OZ. COPPER CLAD BOTH SIDES.
 - PLATED THRU HOLES AND THE CONDUCTIVE PATTERN ELECTROPLATED WITH .001 INCH MIN. THICK COPPER. TERMINAL AREAS AND PLATED THRU HOLES TO BE COATED WITH 60/40 TIN LEAD AND HOT AIR LEVELLED. (SMOBC)
 - PROCESSING TOLERANCES:
 - CONDUCTIVE PATTERN FRONT TO BACK REGISTRATION WITHIN .005 INCH TOTAL.
 - MINIMUM ANNULAR RING SURROUNDING HOLES .005 INCH.
 - FINISHED CONDUCTIVE PATTERN WITHIN .002 INCH OF TRUE SIZE.
 - WARP AND TWIST WITHIN .010 INCH PER INCH.
 - DIMENSIONS: ARE FOR THE FINISHED PART.
 - SOLDER MASK: LIQUID PHOTO IMAGABLE SOLDER MASK OVER BARE COPPER COPPER (SMOBC), COLOR GREEN, BOTH SIDES USING THE PATTERN(S) PROVIDED. NO MASK PERMITTED ON THE TERMINAL AREAS. SOLDER MASK TO ETCH REGISTRATION WITHIN .005 INCH TOTAL.
 - SCREENING: SCREEN COMPONENT OUTLINES AND NOMENCLATURE USING INDELIBLE WHITE INK ON THE COMPONENT SIDE USING THE PATTERN PROVIDED. NOMENCLATURE SHALL BE LEGIBLE. SCREEN TO ETCH REGISTRATION WITHIN .020 INCH TOTAL.
 - SURFACES: PUNCHED OR MACHINED SURFACES 125 MICRO INCHES RMS MAX.
 - BREAK ALL SHARP EDGES .015 R MAX.
 - FABRICATION VENDOR TO ADD UL VENDOR NUMBER IN THIS AREA ON THE CIRCUIT SIDE.

HOLE LEGEND			
SYM	HOLE SIZE	COMMENTS	QTY
●	.032-.038 DIA.	AFTER PLATING	100
■	.035-.041 DIA.	AFTER PLATING	2
○	.043-.049 DIA.	AFTER PLATING	48
⊗	.052-.058 DIA.	AFTER PLATING	4
◇	.059-.065 DIA.	AFTER PLATING	16
□	.106-.112 DIA.	AFTER PLATING	3
⊕	.122-.128 DIA.	AFTER PLATING	4
≡	SLOT(.040 X.090)	AFTER PLATING	2
≡	SLOT(.040 X.090)	AFTER PLATING	1
≡	SLOT(.130 X.030)	AFTER PLATING	2
≡	SLOT(.130 X.030)	AFTER PLATING	1
①	.120-.130 DIA.	DO NOT PLATE	8

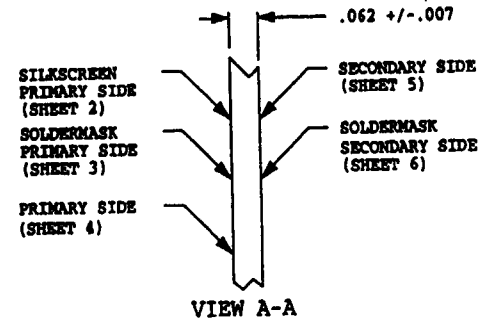

UNLESS OTHERWISE SPECIFIED DIMENSIONS ARE IN INCHES TOLERANCES		DRAWN DATE		ANALOG DEVICES		181 BALLANTRAE STREET WILMINGTON, MASS. 01897	
DECIMALS ANGLES		DESIGN RESOURCES		FABRICATION AD725 EVALUATION BOARD			
.X ± .XX ± .01 .XXX ± .005		CHECKED					
MATERIAL		ENGINEER		CODE IDENT NO. C			
SEE NOTE 1		ENGINEERING MGR.		REV. B			
FINISH		QUALITY CONTROL		AD725			
SEE NOTE 2		PRODUCTION		SHEET 1 OF 6			
APPLICABLE SPECIFICATION		WEIGHT		SCALE 1/1			
NEXT ASST	USED ON	APPLICATIONS					

FEMALE VGA
VGA OUT

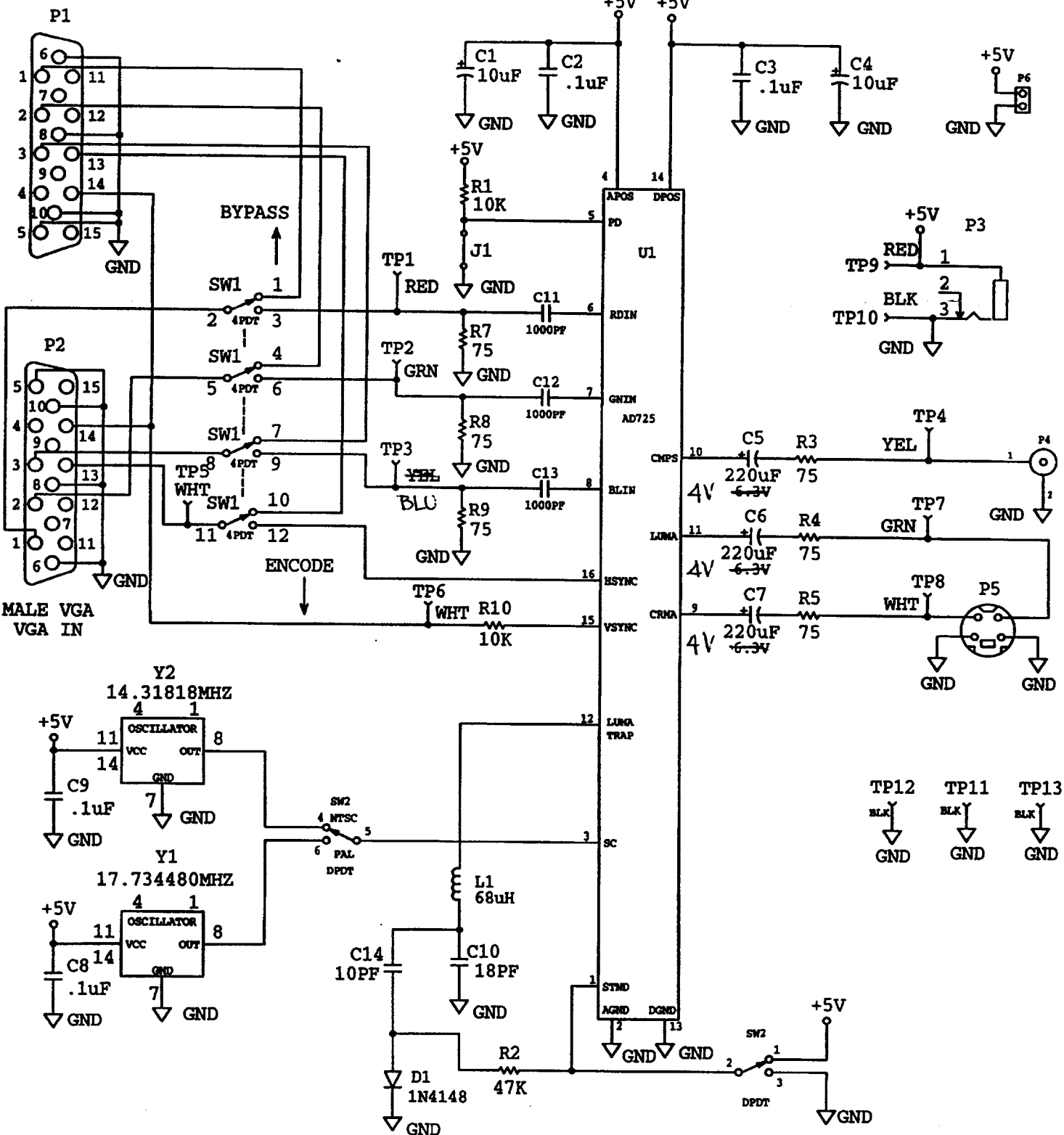

ANALOG DEVICES AD725 REV B